

# ULTRA SONIC TECHNIQUE FOR THE MEASUREMENT OF PRESSURE BELOW ATMOSPHERIC PRESSURE

*Prof. M. Rehman, Eisa Bashier & Dr. Othman Sidek*

School of Electrical and Electronics Engg., University Sains Malaysia, Malaysia

## ABSTRACT

*This paper deals with the theory, fabrication and test results of an ultrasonic technique which is used to measure vacuum in a container. Ultrasonic Transmitter and receiver, working at 40 KHz, are used for conducting the experiments. The sensitivity of measurement is a function of applied voltage to the transmitter. Results on a proto-type model are included and relationship between output voltage and pressure is appreciably linear.*

## 1. INTRODUCTION

Ultrasonic measurement techniques are used extensively in laboratories and industries, finding endless applications from level measurements to non destructive testing and robot navigation. In this paper we are investigating the use of ultrasonic technique for the measurement of vacuum pressure using suitable ultrasonic transducers. As ultrasonic wave gets attenuated while it is traveling through any medium from one place to another, the attenuation depends upon the physical properties of the medium. A continuous ultrasonic wave of 40 KHz has been produced by a transmitter and passed through the medium and received on the ultrasonic transducer working as receiver. The medium pressure was decreased below atmospheric pressure up to 40 K Pascal and the receiver outputs were recorded and correlated to the applied pressure. The measurement was carried with a sensitivity of 0.124mV/ Pascal. This study forms a base for vacuum pressure measurement using ultrasonic transducers.

## 2. PRINCIPLE OF OPERATION

Ultrasonic waves need a medium to travel from one point to the other and every medium has its own properties such as elasticity, pressure, density, temperature, viscosity, etc. The medium properties have a direct effect on the waves passing through them. The easiest obtainable information from the ultrasonic waves, in time domain, is through measuring the waveform attenuation which can be

obtained by measuring the difference in peak levels of the transmitted signal and the received signal. It requires a pulse generator, transmitter–receiver pair and visual device for display. The velocity of sound wave depends on the type of wave, the density and the elastic constant of the material in which it is traveling. The equation that relates the velocity  $v$  of a longitudinal sound wave in air or other fluid having density  $\rho$ , was given by Newton [1]. Later, Laplace pointed out that compression and rarefaction in a sound wave of even moderate frequency were taking place too rapidly for temperature equalizations. Then he proved that the equation given by Newton should be corrected to:

$$v = \sqrt{\gamma P/\rho} \quad \dots (1)$$

Where,  $P$  is the pressure,  $\gamma$  is the ratio of specific heat determined by Roentgen to be 1.405 for air and remain constant for temperature range from  $-80^{\circ}\text{C}$  to at least  $150^{\circ}\text{C}$ . [2][3]

The velocity of sound in air is not independent to its temperature and the new equation for the sound velocity at any temperature  $t^{\circ}\text{C}$  is given by:

$$v_t = v_0 \sqrt{1 + \beta t} \quad \dots (2)$$

Where  $v_0$  is the sound velocity at  $0^{\circ}\text{C}$  and  $\beta = 0.00578/^{\circ}\text{C}$ , is the temperature coefficient of expansion of the gas.

The transmitter and receiver used in this application are piezoelectric transducers which were designed to work properly in air medium. It is well known that the electrical equivalent series resonance circuit of the piezoelectric transducer contains inductance  $L_1$ , capacitance  $C_1$  and a resistor  $R_1$ . At resonance,  $L_1$  and  $C_1$  will drop out leaving  $C_0$  in parallel with  $R_1$  as shown in Fig 1. When this device is working in transmitting mode, the maximum power transfer is obtained by matching the transducer impedance than that of the source; the current through the circuit is limited. If the source impedance is higher than the impedance of the transducer, higher voltage is dropped across the source impedance. In both the cases the electrical power transferred to the transducer element is lower than the maximum and so

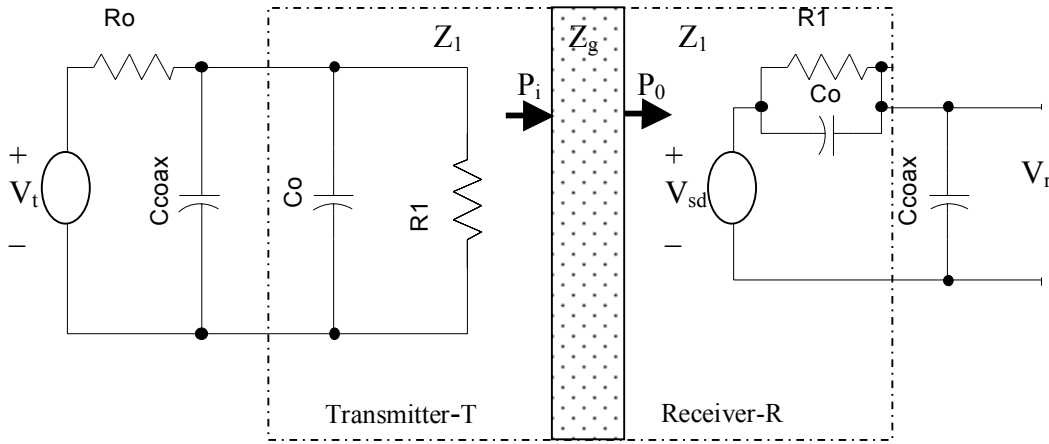

Figure 1: Piezoelectric Transducer equivalent Circuit for transmitting-mode and Receiving-mode

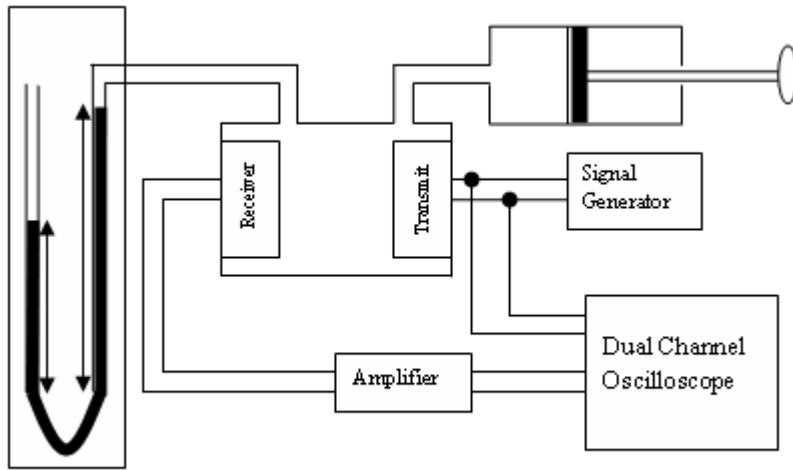

Figure 2: Experimental Setup for Low Pressure Measurement

the mechanical power of it will be received by the piezoelectric is transmitted. This mechanical power propagates through the medium and part of it will be received by the piezoelectric element of the receiver.

The gas density  $\rho_g$  depends on the gas pressure  $P_g$  according to:

$$\rho_g = P_g / RT \quad \dots(3)$$

Where  $R = 289 \text{ J/Kg Kelvin}$  is the universal gas constant divided by the average molecular weight of air,  $T$  is the temperature. For constant temperature the gas density is directly proportional to  $P_g$ .

The acoustic impedance  $Z_g$  of the gaseous medium is given as:

$$Z_g = \rho_g v \quad \dots (4)$$

Putting (3) in (4)

$$Z_g = P_g v / RT \quad \dots (5)$$

Since the ultrasound velocity of gas is independent of pressure and it is a function of temperature only as seen from equation (5), for constant temperature the acoustic impedance  $Z_g$  of the gas is directly proportional to its pressure  $P_g$ .

### 3. EXPERIMENTAL SETUP AND RESULTS

The proposed measurement technique was experimentally examined over pressure range from atmospheric pressure to 40K Pascal. The experimental setup for the measurement is shown in Fig 2. The reservoir serves as a medium which has two taps; one was connected to a piston for changing the pressure of the medium while the other tap was connected to a U-tube manometer, which measures the pressure variations. Inside this reservoir is pair of ultrasonic transducers (transmitter-T and receiver-R). The piezoelectric transmitter was driven using a continuous sinusoidal wave of constant amplitude and 40 KHz frequency. This signal is received by the

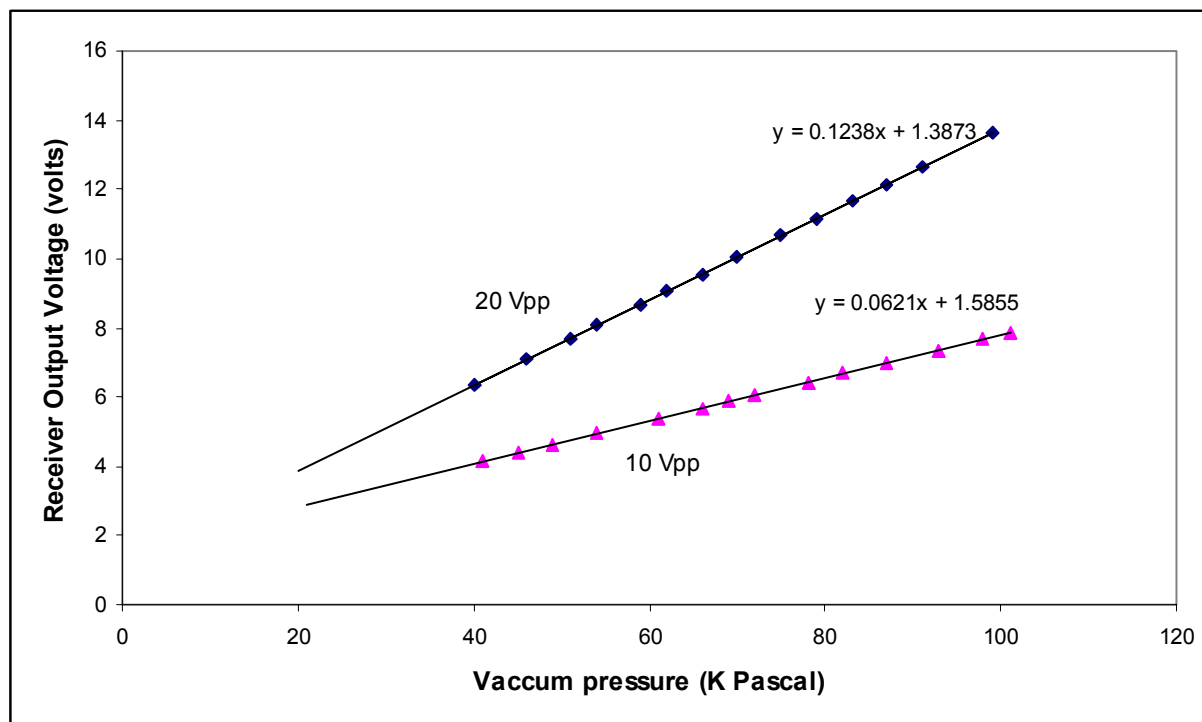

Fig 3. Variation of Output Voltage with change in Pressure

receiver after propagating through the medium whose pressure is decreased in steps. Received signal was amplified and displayed on a dual channel oscilloscope. Figure 3 shows the experimental relationship between the output voltage and decreasing pressure. In the range of measurement, this relation was found to have a pattern containing two components; one is directly proportional to the pressure of medium while the other is approximately constant, which corresponds to the loss due to geometrical spreading, molecular relaxation, boundaries etc. Observations have been taken at two applied voltages i.e. 10V and 20V and results are shown in Fig.3 when pressure was decreased from atmospheric pressure to a pressure 40kPascal below atmosphere. The nature of characteristics matches with the theory developed. The experimental results are found to be more sensitive to the higher applied voltage as the slope of the line gets doubled for double input voltage. The measurements were carried out at constant temperature of 26°C.

#### 4. CONCLUSIONS

The measurement of low vacuum pressure, using ultrasonic technique, is successfully implemented. The acoustic impedance of the medium plays important role in the transfer of energy between the transmitter and receiver. Irrespective of the amount of this energy at atmospheric pressure, received energy is continuously decreasing with the decrease in the

pressure of the medium separating the ultrasonic transmitter and receiver. After calibration it is found that the relationship between the pressure of the medium and the output voltage of the receiver can be represented by a straight line. This method is relatively simple, direct and inexpensive. The results of this study suggest that the ultrasonic technique can be utilized for the measurement of vacuum pressure and transmitter as well as receiver may be placed either inside the container or outside the container.

#### 5. REFERENCES

- [1] M.Y.Colby, 1958, "Sound Waves & acoustics", Henry Hot &Company, Inc., pp.127-133.
- [2] David Webster 1994 "A Pulsed Ultrasonic Distance Measurement System Based on Phase Digitizing", *IEEE Trans. Instrum. And Meas. Vol-43, No. 4: pp 578-582.*
- [3] C. Canali, G. DeCicco, B. Morten, M. Prudenzioli, and A.Taroni, 1982, "A Temperature Compensated ultrasonic Sensor Operating in Air for Distance and Proximity Measurements", *IEEE Trans. Indust. Electro. Vol-29, No. 4: pp 336-341.*
- [4] R. Goldman 1992 "Ultrasonic Technology," Reinhold Publishing company, New York.