

Master-Slave Speed Control of Double Induction Motor

¹Ahmed A.M. Emam, ²Eisa B. M. Tayeb, ³A.Taifour Ali and ⁴Musab M.S.A. Alshiekh

¹ College of Engineering, Karrary University; SUDAN

^{2, 3, 4} College of Engineering; Sudan University of Science & Technology; SUDAN

ABSTRACT:

Induction motor is one of the main sources of mechanical energy in industry; several applications use more than one motor to bear the high load. This paper is concerned with the design of a master slave control system responsible for synchronization between the different motors. The concept of the field oriented control (foc) is explained. PI-field oriented controllers are designed for two induction motors in master slave configuration. The proposed control system is simulated using Matlab/Simulink. The simulation results showed good synchronization between the master and the slave motors with acceptable tracking error.

Keywords: induction motor, synchronization problem, master-slave control, field oriented control (FOC).

I. INTRODUCTION

Induction machine with drive systems are widely used in applications such as pumps, paper and textile mills, elevators, electric vehicle and subway transportation. Industrial drive applications are generally classified into constant-speed and variable-speed drives. Traditionally, AC machines have been used in constant-speed applications [1]. DC machines were preferred for variable-speed drives. Variable speed Induction Motor has been used widely for the industrial applications. Synchronization techniques can be implemented by using high efficiency induction motor. The Existing techniques used are Master-Slave, Cross Coupling Technique, and Bi-axial cross coupled control method [2]. Simulink model of an induction machine is described, and then this model is used in different drive applications, such as open-loop constant V/Hz control, indirect vector control, and master slave control [3-5].

In this work one of the motors has been used as a master and the other one as slave, the speed of the master motor represents a reference signal for a close loop control system that controls the speed of the slave motor to track the speed of the master. A control methodology for various models of the induction machine, including conventional control, is used to study and simulate the system using MATLAB software.

II. SYSTEM MODELING

Figure (1) shows the Simulink d^e-q^e model of the induction motor. The model receives the input voltages V_{qs} and V_{ds} and frequency ω_e and solves the output currents i_{qs} and i_{ds} with the help of flux linkage equations. Extensive discussion of this model was introduced in [6].

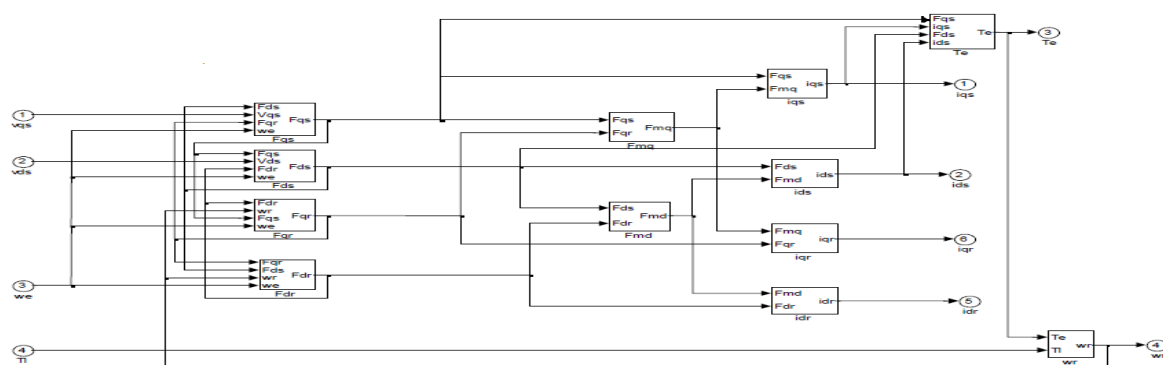

Figure (1) Induction Motor Model

Figure (2) shows the simple simulation block diagram for a three-phase, two-level PWM inverter. Each leg of the inverter is represented by a "switch" which has three input terminals and one output terminal. The output of a switch (v_{ao} , v_{bo} , or v_{co}) is connected to the upper input terminal (+0.5Vd) if the PWM control signal (middle input) is positive. Otherwise, the output is connected to the lower input terminal (-0.5Vd). Extensive discussion of this model was introduced in [7].

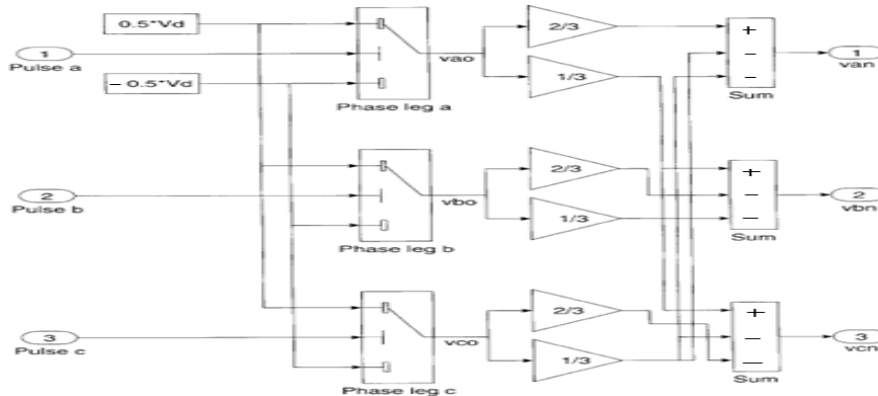

Figure 2 PWM Inverter Model

III. MASTER-SLAVE CONTROL TECHNIQUE

Master-Slave control technique is used for synchronization of double-motors. Its main characteristic is that the revolving speed output of the master motor is used as a reference value of the slave motor. Any input signal or disturbance on the master motor can be reflected and followed by the slave motor [8]. Figure (3) shows the adopted master slave configuration.

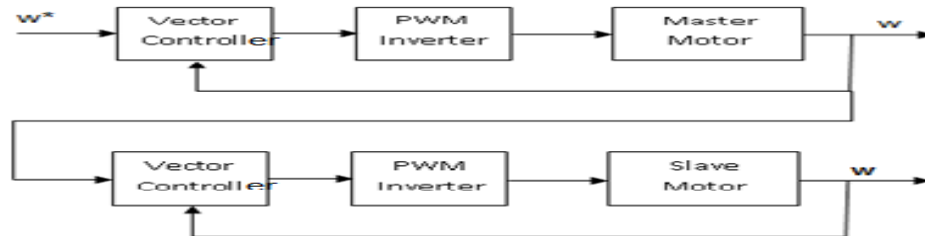
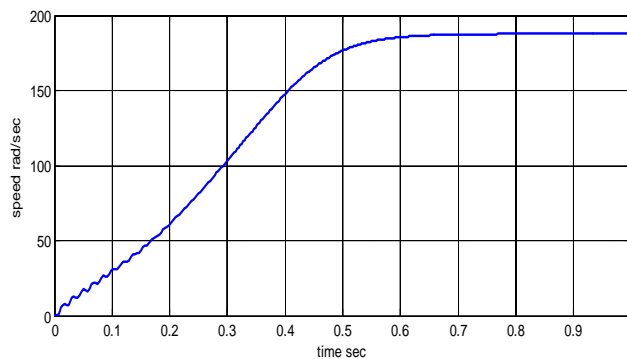

Figure 3 Master-slave Control Method

IV. SIMULATION RESULTS

Direct start-up test of the model was done by applying a three-phase programmable voltage source with 460 volt, 60 Hz. The simulation of the dynamic speed, torque and stator current of the induction machine is shown in figure 4.



(a) Motor Speed

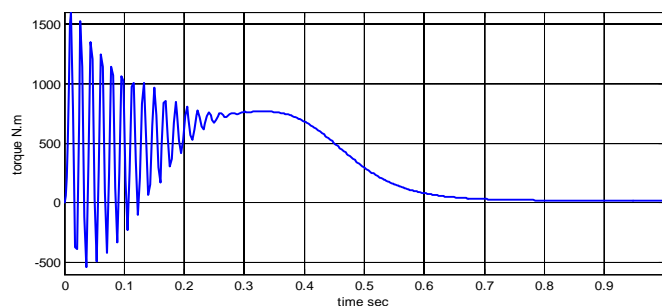

(b) Motor Torque

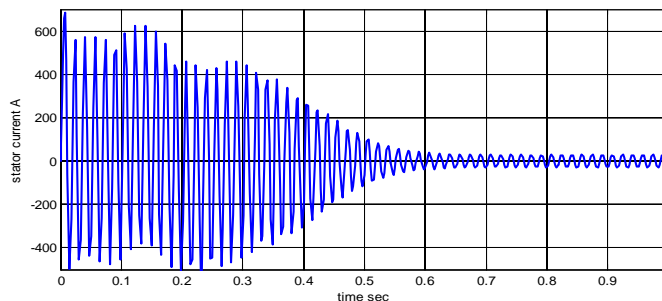

(c) Motor Stator Current

Figure 5 Induction Motor Dynamics using direct start-up test

In the indirect vector control the reference speed and the load torque applied to the motor shaft can be both selected by a manual switch block in order to use either a constant value or a step function. The simulation of indirect vector control of motor drive is shown in figure 6, as shown the system had poor transient response.

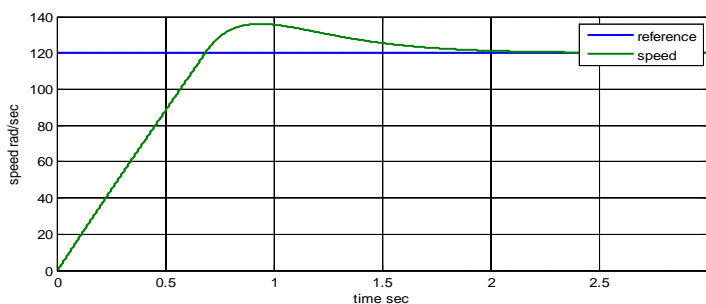

Figure 6 Speed of Motor Using Indirect Vector Control

The Simulink model of master-slave control was formed by combining a vector control block to the master motor, so that the master motor can operate at any desired speed as shown in figure 7. The simulation of master close loop system is shown in figure 8. It is obvious that the transient response is so good.

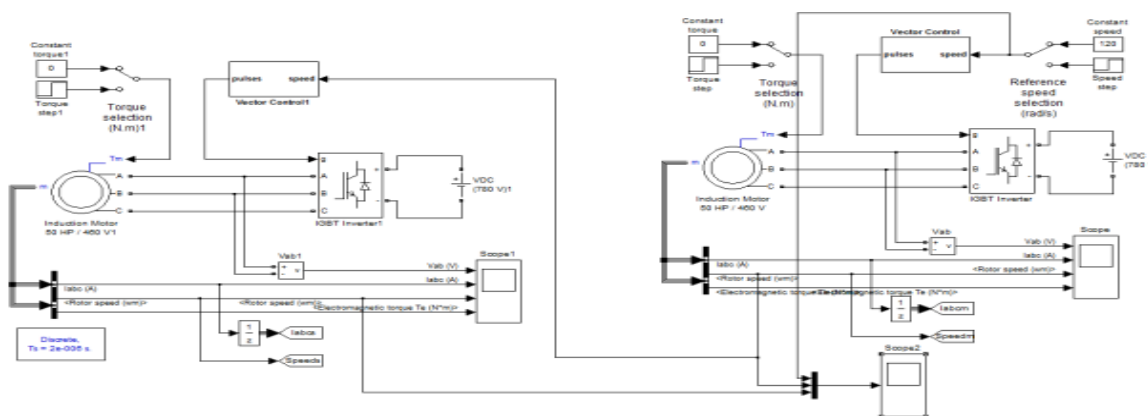
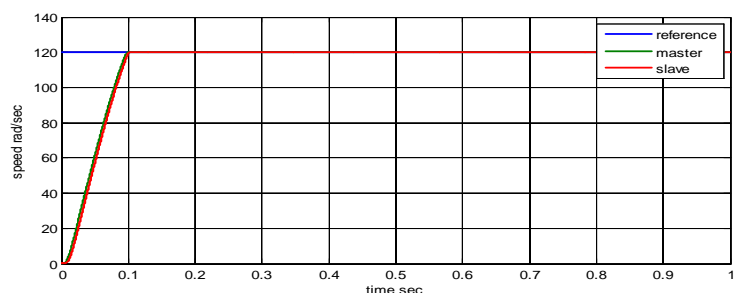
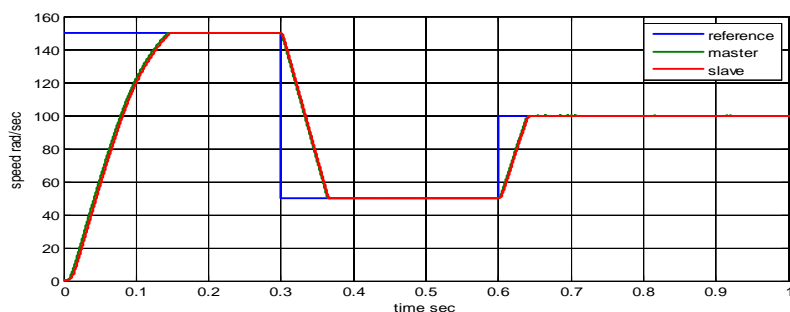

Figure 7: Simulink Model of Master-Slave Control



(a) Speed response in regulation mode



(b) Speed response tracking a variable reference (R1)

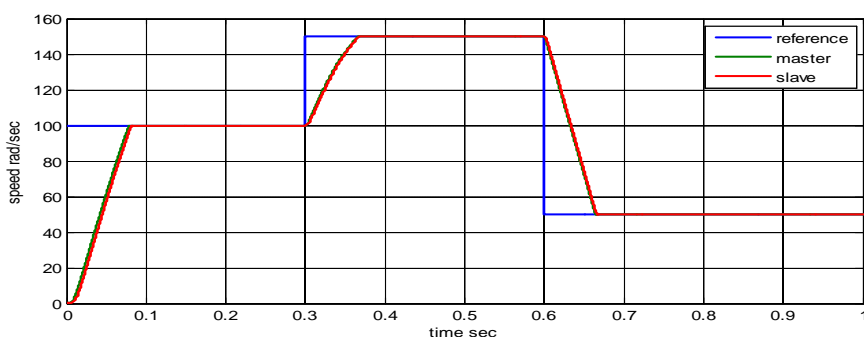

(a) Speed response tracking a variable reference (R2)

Figure 8 Speed Response of Master and Slave motors

V. CONCLUSIONS

In this paper all objectives are investigated, and master slave control is applied in the double induction motor synchronized system, which is so widely used in the industry. Master slave control strategy with FOC proves to be effective for synchronization of double-motor system with fast speed response, short setting time, stronger robustness and less overshoot. Such performance can hardly be achieved by traditional PI speed control.

REFERENCES

- [1] R. G. Shriwastava, M.B.Diagavane, S.R.Vaishnav 2012“Literature Review of Permanent Magnet AC Motors Drive for Automotive Application” Bulletin of Electrical Engineering and Informatics), Vol.1, No.1, March 2012, pp. 7-14
- [2] Aron van Zijl, "Master-Slave Motor Control", Eindhoven University of Technology Department of Electrical Engineering Group MBS, Measurement and Control Section.
- [3] A A Ansari, D M Deshpande, "Mathematical Model of Asynchronous Machine in MATLAB Simulink" International Journal of Engineering Science and Technology Vol. 2(5), 2010, 1260-1267.
- [4] Hoang Le-Huy "Modeling and Simulation of Electrical Drives using MATLAB/Simulink and Power System Block-set". IEcon'01: The 27th Annual Conference of the IEEE Industrial Electronics Society.
- [5] M. SajediHir, Y. Hoseynpoor, P. MosadeghArdabili, T. PirzadehAshraf "Modeling and Simulation of Induction Motor Drive with Space Vector Control", Australian Journal of Basic and Applied Sciences, 5(9): 2210-2216, 2011 ISSN 1991-8178.
- [6] Burak Ozpineci, Leon M. Tolbert "Simulink Implementation of Induction Machine Model– A Modular Approach" IEEE 2003, pp 728-734.
- [7] Bimal K. Bose, "Modern Power Electronics and AC Drives", Prentice Hall, 2002.
- [8] Biao YU, Hui ZHU and Chi XUE," Research on Adaptive Fuzzy PID Synchronous Control Strategy of Double-Motor", *I.J. Intelligent Systems and Applications*, 2011, 5, 28-33 Published Online August 2011 in MECS.